

OPERATING INSTRUCTIONS

FOR

CONSEW

MODELS

223, 223R

227, 227R

227B, 227BR



CONSOLIDATED SEWING MACHINE



A U.S. INDUSTRIES COMPANY.

And that makes a world of difference.

SPECIFICATIONS

SPEED : Maximum 3000 r.p.m.
(With reverse stitch mechanism or
with synchronized binder 2800 r.p.m.)

NEEDLE : 135×17

HOOK : Rotating hook

STITCH LENGTH : Maximum 5 mm

SIZE OF BED : 65φ×269 mm

MOTOR : 250W, 2P, clutch motor

DIAMETER OF MOTOR PULLEY : 50 cycle 70 mm
60 cycle 60 mm

CONTENTS

	Page
Setting up the machine	2
Speed	3
Oiling	3
Needle and thread	6
Inserting and removing the bobbin.....	6
Winding bobbins	8
Threading the machine	9
Regulating the thread tension	10
Regulating the pressure on goods	11
Adjusting the stitch length.....	11
Adjusting the lift of the alternating presser feet.....	12
How to re-set the safety clutch mechanism.....	12

INFORMATION FOR ADJUSTMENT

Replacement of the timing belt	13
Adjusting the height of the feed dog	14
Adjusting the timing of the needle plate, needle and feeder.....	14
Adjusting the height of the needle bar.....	15
Timing between the needle and hook	15
Relative position between bobbin case and opener	16
Adjusting the height of the presser feet	16
Timing of the vibrating presser foot	17
Adjusting the thread controller spring	17
Instructions for 227B or 227BR only	18

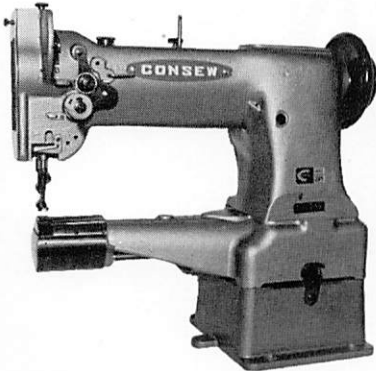

227

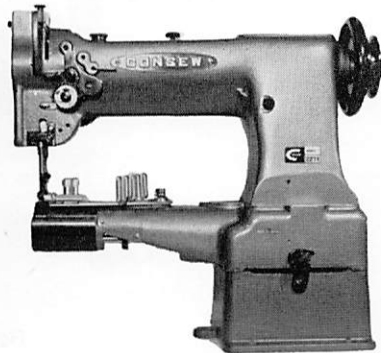

227B

SETTING UP THE MACHINE

Before setting up the machine on the table, attach the relative parts to the table.

- | | | |
|------------------|---------------------|-----------------|
| 1. Motor | 2. Stand | 3. Treadle |
| 4. Pedal | 5. Machine rest pin | 6. Cotton stand |
| 7. Machine base | 8. Head | 9. Chain |
| 10. V shape belt | 11. Bobbin winder | |

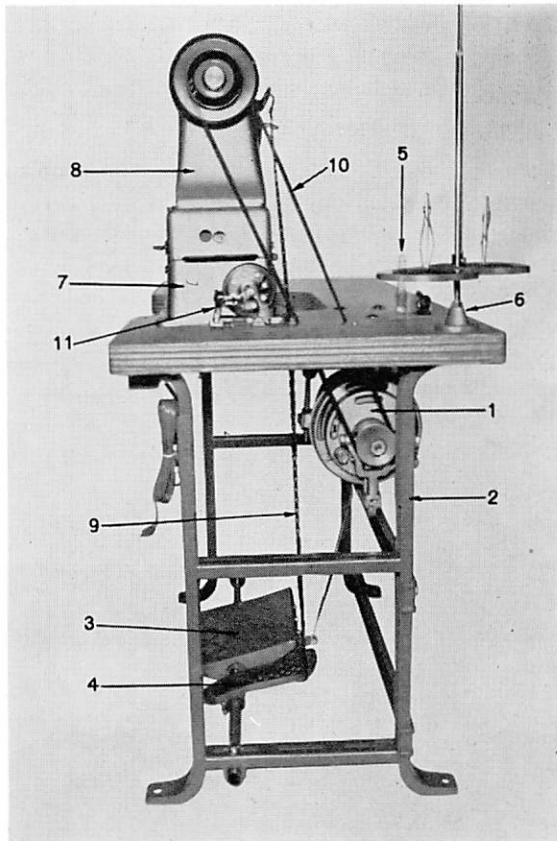

Fig. 1

SPEED

Maximum operating speed after a break-in period is 3000 stitches per minute depending, of course, on the type of material being sewn, its thickness and that of seams being crossed. (In case of the machine with reverse lever or synchronized binder 2800 r.p.m.)

To assure durability and trouble-free operation, it is recommended that for the first several weeks of operation the maximum speed is held to not more than 2400 RPM in order to allow the parts to become properly broken in.

In operation the hand wheel of the machine always turn toward the operator.

OILING

Do not operate the machine, even if only for testing, unless it has been properly oiled at every spot requiring lubrication.

The arrows on the Figs. 2, 3, 4 and 5 indicate these spots.

Oiling must be done at least twice daily when the machine is in continuous operation to assure free running and durability of the operating parts.

The hook mechanism should receive careful attention when lubricating the machine.

The oil well beneath the hook should be filled with oil and the felt pad in the same should be soaked with oil. In case of a new machine, oil pad every time a new bobbin is inserted.

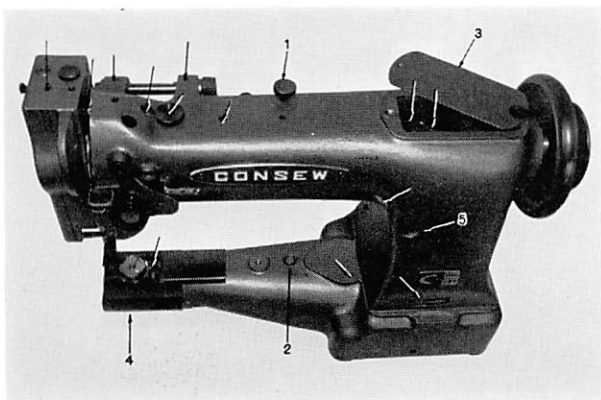

Fig. 2

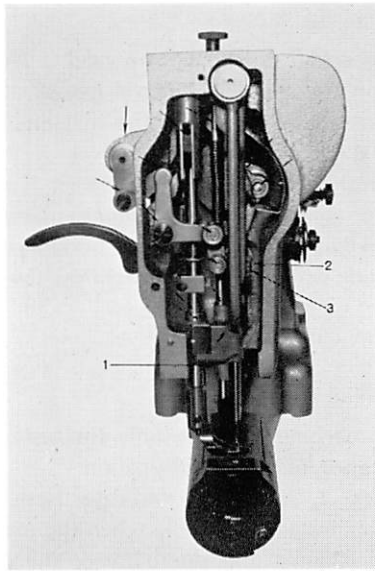

Fig. 3

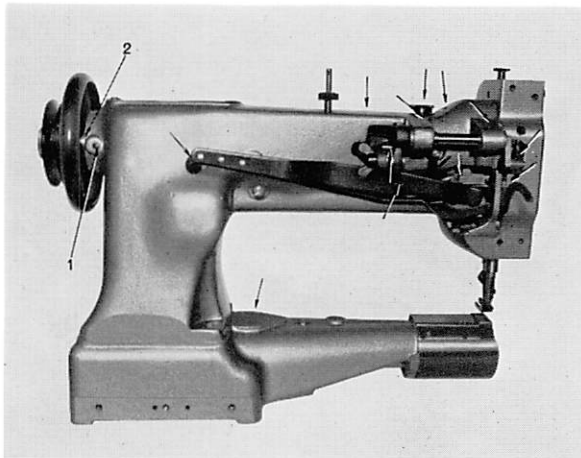

Fig. 4

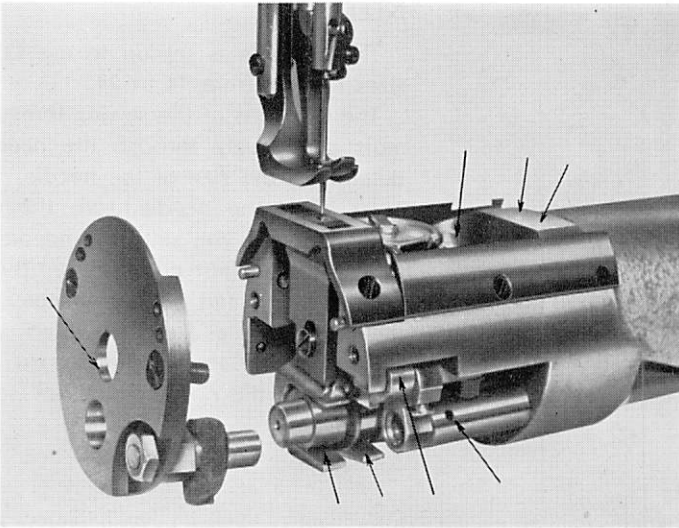

Fig. 5

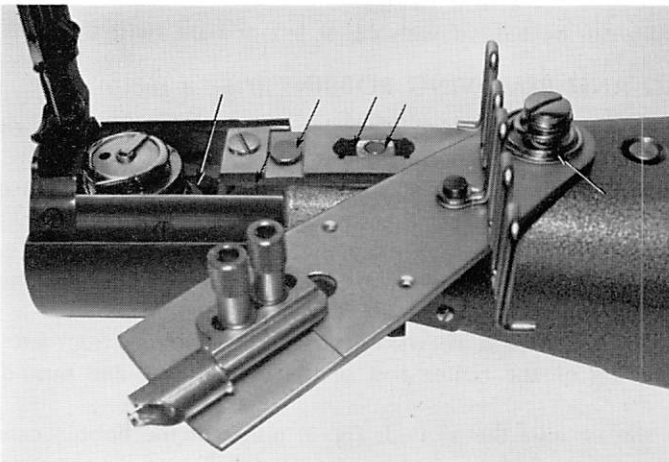

Fig. 6

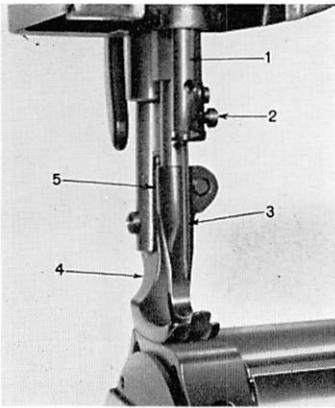

Fig. 7

NEEDLE

The machine is set up to use 135×17 in sizes ranging from 14 to 24.

The thickness of the sewing thread, which must pass freely through the needle eye, determines the size of the needle.

To insert the needle, turn the machine pulley toward you until the needle bar (1) raises to its highest point, loosen the needle set screw (2), and put the needle up into the needle bar as far as it will go, with the long groove of the needle toward the left, and tighten the needle set screw securely.

THREAD

Cotton, synthetic, silk thread can be used according to your sewing purpose, the thickness of thread available is up to #8.

Only left twist thread is to be used for the needle, to test for twist, hold a length of thread between thumbs and index fingers of your hands. Turn the thread counterclockwise.

If it will twist tighter, it has a left twist.

If it unravels, it has a right twist.

The bobbin can be wound with either left or right twist thread.

INSERTING AND REMOVING BOBBINS (Figs. 8 and 9)

1. Raise the needle bar to its highest point. Push open the right-hand cover plate (1, Fig. 8) on the arm of the machine.

Pull up the latch (2, Fig. 8) and lift the bobbin from the bobbin case.

In case of the binding machine with a synchronized binder, lift slightly the serrated nuts (1, Fig. 9) and pull open the plate (2, Fig. 9) toward you.

2. To insert a full bobbin, hold it on one of its sides between thumb and index finger of your right hand.

Be sure that the thread draws out from the bobbins from left to right. Place the bobbin on the center post of the bobbin case and push down the latch (2).

Pull the thread into the slot (3, Fig. 8) inside of the bobbin case and to the left between the bobbin case opener (4, Fig. 8) and a projection (5, Fig. 8) and under the tension spring (6, Fig. 8).

Draw out about 5 cm of the thread on the needle plate and close the cover plate, but leave sufficient space for passage of the thread.

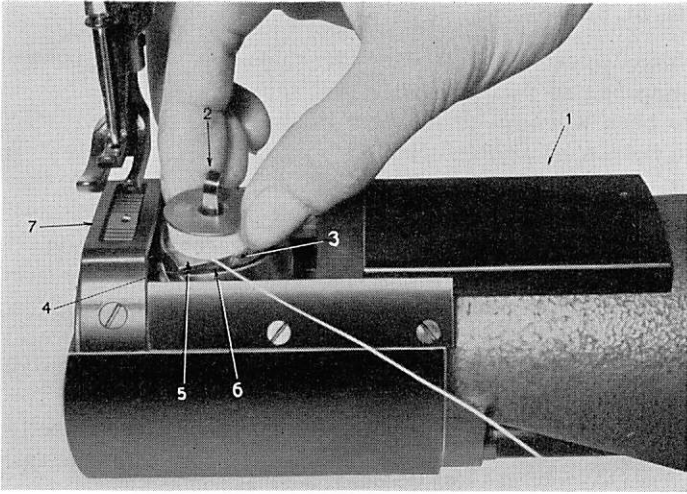

Fig. 8

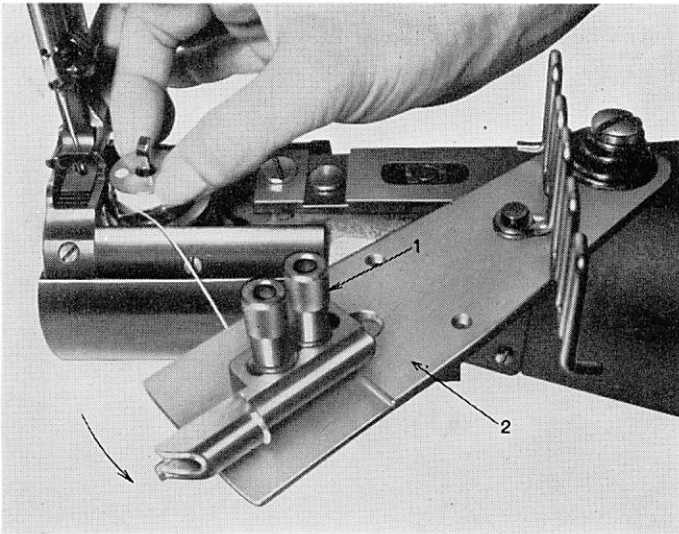

Fig. 9

WINDING BOBBINS

The bobbin winder is mounted on the table top with its pulley in front of the driving belt so that the pulley will separate from the belt after the bobbin has been wound with sufficient thread.

Push the bobbin on bobbin spindle (1, Fig. 10) as far as it will go. Pass the thread from thread stand downward through the eye in the tension bracket. Then between and around the back of the tension discs, bring the thread forward toward the bobbin and wind from below in clockwise direction several times around the bobbin. Push bobbin winder lever (3, Fig. 10) downward until the wheel (2, Fig. 10) contacts the drive belt and start the machine.

After bobbin is filled with thread, release will cause the wheel to disengage from the belt and winding will stop.

Cut the thread and remove the bobbin from the winder spindle.

The adjustment screw (5, Fig. 10) can be turned in or out to increase or decrease the amount of the thread wound on the bobbin.

When fine thread is wound on bobbins, use light tension. It is regulated by turning the knurled nut (6, Fig. 10) on the tension bracket at the rear of the bobbin winder.

Bobbin can be wound while the machine is sewing.

If the thread does not wind evenly on bobbins, loosen the screw (4, Fig. 10) and move the bracket to the right or left as may be required, then tighten the screw.

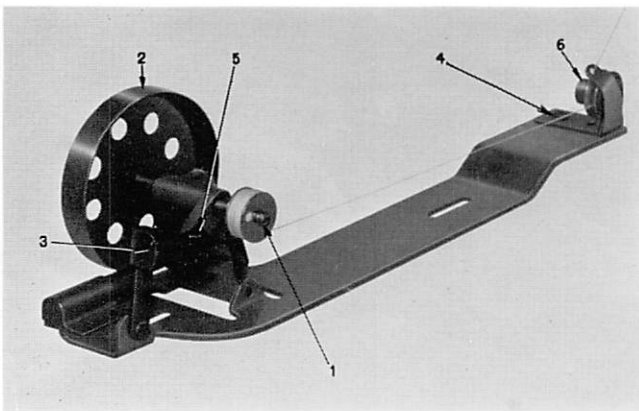

Fig. 10

THREADING THE MACHINE

Raise the needle bar to its highest point.

From the thread stand lead the thread from back to front through the lower guide hole in the spool pin (1) on the top of the machine arm, then again from right to left through the upper guide hole in this pin.

Pass the thread in weaving fashion through the three holes in the guide (2), and from right to left over and between the tension discs (3). Now pull the thread downward and from right to left beneath and around the thread controller (4), continue to pull the thread upward against the pressure of the wire spring into the fork (5) in the thread controller.

Guide upward through the thread guide (6) and from right to left through the eye in the take-up lever (7), down through the thread guide (6) again and then through (8), (9) and (10) from left to right through the eye of the needle.

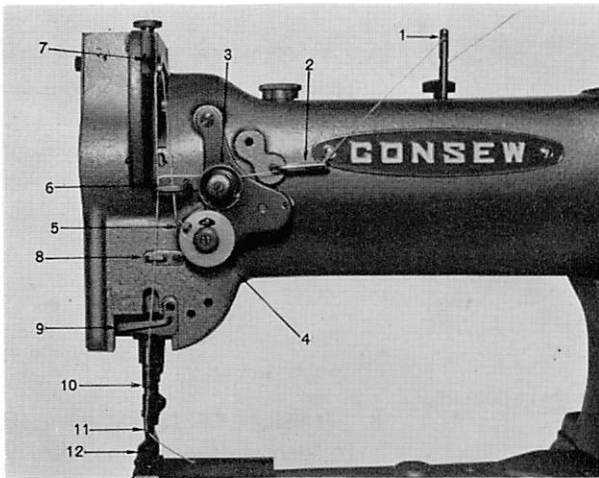

Fig. 11

REGULATING THE THREAD TENSIONS

For ordinary stitching, the tension of the upper and lower threads should be equal so as to lock both threads in the center of the fabric. If the tension on either thread is stronger than on the other, imperfect stitching will be the result.

If the tension on the upper thread is greater than that on the lower thread, it will be straight along the upper surface of the fabric.

If the tension on the lower thread is greater than that on the upper thread, the lower thread will lie straight along the underside of the fabric.

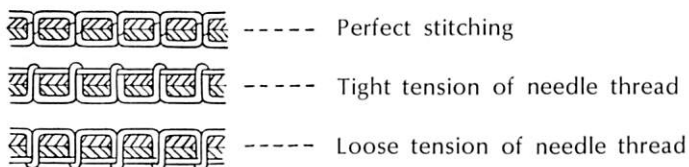

Fig. 12

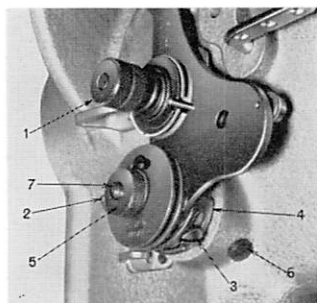

Fig. 13

A. TENSION OF THE UPPER THREAD

To adjust the tension of the upper (needle) thread, turn the serrated nut (1) to the right for increasing tension. If you desire to decrease it, turn the nut to the left.

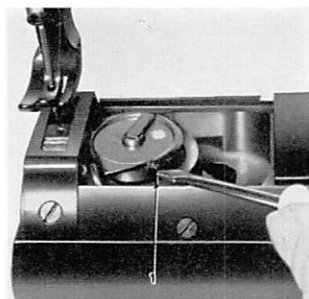

Fig. 14

B. TENSION OF THE BOBBIN THREAD

To increase the tension, turn the screw (1) to the right, and to decrease it turn the screw to the left by a screw driver.

ADJUSTMENT OF THE PRESSURE ON GOODS

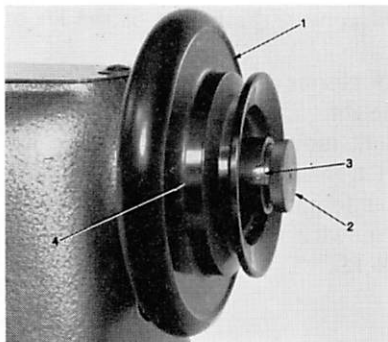

Fig. 15

The pressure of the presser feet is regulated by the adjusting screw (1, Fig. 2).

To increase the pressure, turn the screw to the right, and to decrease it to the left.

ADJUSTING THE STITCH LENGTH

Numerals on pulley show number of stitch per inch	Stitch length (m/m)
3	9
4	6.5
5	5
6	4.2
7	3.6
8	3.2
9	2.8
10	2.5
12	2.1
16	1.6
20	1.2
24	1

In case of the machine without reverse lever, the length of the stitch is adjusted by turning the serrated knob (2, Fig. 15). It will be noticed that there is a notch (3, Fig. 15) in this hub wherein appears a number. Same indicates the approximate number of stitches per inch.

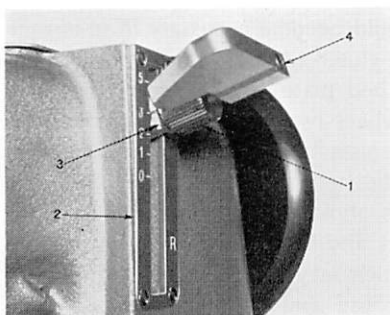

Fig. 16

On the occasion of the machine with reverse stitch mechanism, it is adjusted by turning the serrated nut (1, Fig. 16) so that the reference mark on the collar (3, Fig. 16) comes in line with the desired number of stitch length on the plate (2, Fig. 16).

The numerical numbers on the plate show millimeter.

When making reverse stitch, push the lever (4, Fig. 16) down as far as it will go.

ADJUSTING THE LIFT OF THE ALTERNATING PRESSER FEET

The thickness of the material sewn should control the height of the lift of the alternating presser feet.

It should normally be just high enough for clearance of the material. With normal adjustment both feet lift to equal height.

To adjust the lift, loosen the wing nut (1), move up the nut to raise the lift, and push down this nut to lower the lift.

When altering the lift of the lifting presser foot (4, Fig. 7) unequally against that of the vibrating presser foot (5, Fig. 7) or vice versa, see the instructions "ADJUSTING THE HEIGHT OF THE PRESSER FEET".

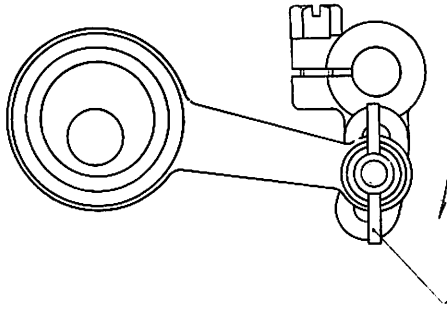

Fig. 17

HOW TO RE-SET THE SAFETY CLUTCH MECHANISM

The sewing hook and its mechanism are protected by a safety clutch. In case the hook gets jammed with thread or other foreign matter, the safety device disengages the driving belt, stops sewing, and thus prevents the machine from getting damaged.

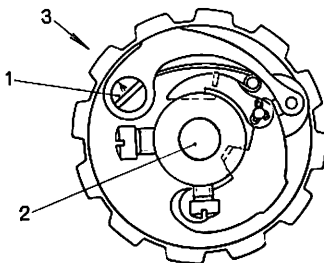

Fig. 18

If it should become necessary to re-engage the safety clutch, depress the button (2, Fig. 2) in the bed plate, at the same time, turn the handwheel away from you until the locking mechanism re-engages the driving shaft beneath the bed of the machine, open the slide plate above the hook and rock handwheel back and forth to remove any foreign matter which may have lodged in the hook.

Do not use any sharp-edged tools, lest the hook be damaged.

REPLACEMENT OF THE TIMING BELT

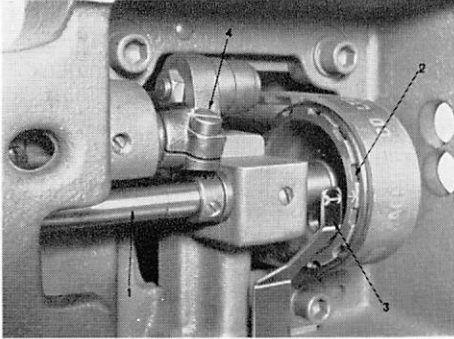

Fig. 19

1. INSERTING THE BELT

Turn the hand wheel toward you until the take-up lever reaches to its highest point.

Turn the lower shaft (1, Fig. 19) until the arrow mark on the lower belt pulley (2, Fig. 19) comes in line with another arrow on the timing plate (3, Fig. 19).

Insert a new timing belt into the belt pulley at this position.

2. REMOVING THE TIMING BELT

Move the machine top cover (2, Fig. 3), remove the timing belt from the belt pulley. Loosen the collar set screw (1, Fig. 20), draw out the feed regulating dial (2, Fig. 15) from the arm shaft.

Loosen the two set screws (4, Fig. 15), draw out the hand wheel (1, Fig. 15) from the arm shaft.

Loosen the set screw (1, Fig. 4) and draw out the rear bushing (2, Fig. 4) through the arm hole.

Removing and inserting the timing belt is made through the hole drawn out the rear bushing.

After inserting a new belt, replace the arm top cover, screws to their original places securely.

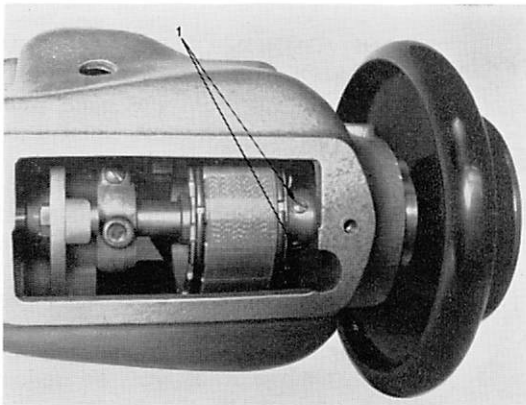

Fig. 20

ADJUSTING THE HEIGHT OF THE FEED DOG

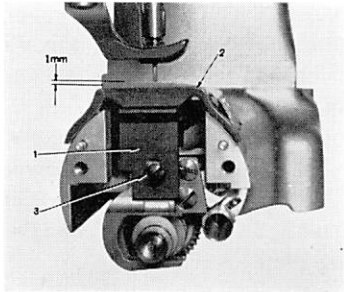

Fig. 21

Securely tighten the screw and replace the cylinder.

The maximum height of the feed dog (1) from the surface of the needle plate (2) is normally 1 mm. (In case of the machine with the synchronized binder, the height of the feeder should be equal to the surface of the needle plate).

To adjust this height, turn the hand wheel so as to raise the feed dog to its highest point.

Draw out the cylinder (4, Fig. 2).

Loosen the set screw (3), adjust the height of the feeder by raising or lowering it.

ADJUSTING THE TIMING OF THE NEEDLE PLATE, NEEDLE AND FEEDER

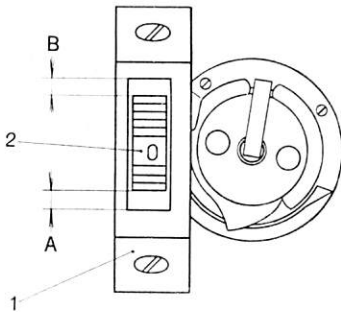

1. RELATIVE POSITION OF THE FEEDER TO NEEDLE PLATE

Adjust the feed motion to the maximum and loosen the screw (4, Fig. 19).

Set the position of the feeder so that both clearances A and B (Fig. 22) are equal before starting feed motion and after finishing the feed.

Securely tighten the screw.

Fig. 22

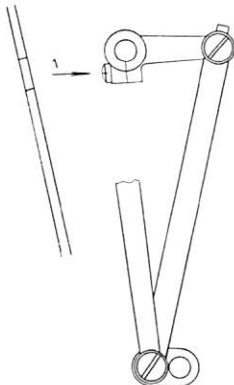

Fig. 23

2. THE POSITION OF THE NEEDLE AND NEEDLE HOLE OF THE FEEDER

To adjust this, turn the hand pulley to raise the needle bar to its highest point and put a perfect needle.

Turning the hand wheel to lower slowly the needle bar, check whether the needle descends to the center of the needle hole of the feeder or not.

If the needle does not enter into the center of the hole, loosen the screw (1, Fig. 23) through the window of the arm (5, Fig. 2).

Holding the bottom of the needle bar rock frame (1, Fig. 3) move it as may be required to get the correct position to the feeder. Then, tighten the screw.

ADJUSTING THE HEIGHT OF THE NEEDLE BAR

1. When the needle bar is at its highest point, normally the measurement between the surface of the needle plate and the upper end of the needle eye is 21.1mm (in case of the machine with the synchronized binder, it is 19.3 mm).

To adjust this, loosen the screw (2, Fig. 3), move the setting position of the needle bar and needle bar connecting stud (3, Fig. 3) to get the correct position. Then tighten the screw.

2. There is another method for this adjustment by setting the needle bar to its lowest point.

The normal position, in this case, is 4 mm approximately from the hook point to the upper end of the needle eye.

NOTE: These measurements are approximate standard, accordingly, following final adjustments are recommended.

TIMING BETWEEN THE HOOK AND NEEDLE

After setting the needle bar height as stated 1. or 2., confirm as follows :

Set the stitch length to 0, turn the hand wheel to lower the needle bar to its lowest point, turn the hand wheel toward you.

When the needle raises 1.9 mm from the lowest point of its travel, normally the hook point is at the center of the needle and the measurement between the hook point and the upper end of the needle eye should be 2.1 mm, further the clearance between the hook point and the needle hollow should be about 0.05 mm to 0.2 mm.

If they are not measured as above, adjustments are made as follows :

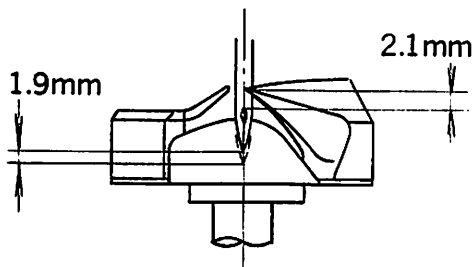

Fig. 24

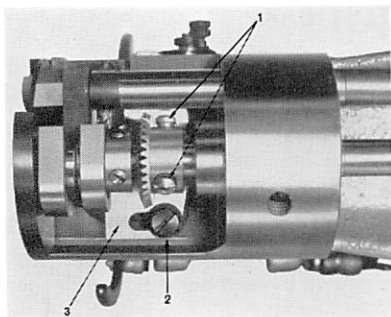

Fig. 25

1. TIMING ADJUSTMENT

Loosen three set screws (1, Fig. 25), set the correct timing by moving the hook. Then tighten the screws securely.

2. ADJUSTING THE CLEARANCE

Loosen the screw (2, Fig. 25) and the set screw (1, Fig. 25).

Move the hook saddle (3, Fig. 25) to the right or left to get the proper clearance and tighten the screws.

Be sure to use perfect needle.

RELATIVE POSITION BETWEEN BOBBIN CASE AND OPENER

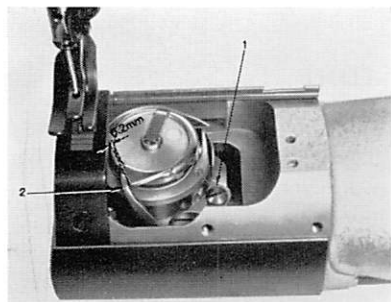

Fig. 26

1. Loosen the screw (1), turn the hand wheel until the opener (2) is located at the extreme right hand position of its travel.

2. In this position, adjust it so that the clearance between the inside edge of the opener and the tab on the bobbin case holder is about 0.2 mm.

After the adjustment, tighten the screw.

ADJUSTING THE HEIGHT OF THE PRESSER FEET

1. ADJUSTMENT BY THE PRESSER BAR LIFTER

Loosen the screw (1, Fig. 2) sufficiently, raise the presser bar lifter and loosen the set screw (1, Fig. 27).

Move the lifting presser foot (4, Fig. 7) up or down as may be required so as to get the correct height and tighten the screw.

2. ADJUSTING THE LIFT OF ALTERNATING PRESSER FEET

On the model 227, 227R, 227B and 227BR if the height of the lifting presser foot changes, the momentums of the lifting and vibrating presser foot vary, thus the height of the vibrating presser foot must be adjusted.

A. Lower the presser bar lifter, holding the vibrating presser foot (5, Fig. 7), loosen the hexagon screw (2, Fig. 27) and move the presser foot up or down as may be required.

B. After setting the position, tighten the screw.

Normally, the momentums of the alternating presser feet are adjusted to equal, but for piping work, it is effective to adjust less momentum of the vibrating presser foot than that of the lifting presser foot.

TIMING OF THE VIBRATING PRESSER FOOT

This is the normal timing when, turn the balance wheel toward you, after lowering the presser bar lifter, the vibrating presser foot should reach the feeder earlier than the needle eye comes to, and when the needle raises, the vibrating presser foot should leave the feeder after the needle eye has left the feeder.

This is due to the reason that the vibrating presser foot must tightly hold the goods while the needle is passing the goods for avoiding irregular stitches.

To adjust this, set the lift of the alternating presser feet to equal, loosen the two screws (3, Fig. 27) and adjust the rotating position of the cam (4, Fig. 27) faster or slower as may be desired, and tighten the screw.

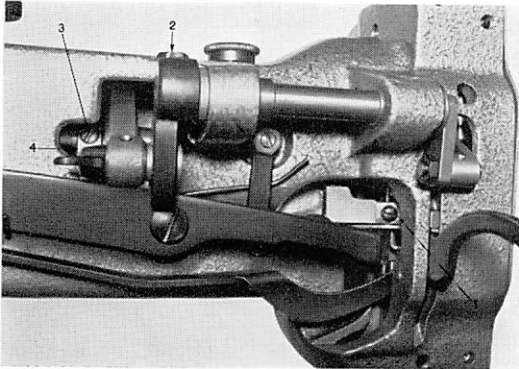

Fig. 27

ADJUSTING THE THREAD CONTROLLER SPRING

Normally the thread controller spring (2, Fig. 13) should hold slack of the upper thread until the needle reaches to the goods, and it should pause while raising of the needle and passing of the upper thread through the bobbin case.

For more controller action on the thread, loosen the stop screw (3, Fig. 13) and move the stop (4, Fig. 13) to the right.

For less action, set the stop to the left. Then tighten the screw.

To strengthen the tension of the spring, loosen the serrated nut (5, Fig. 13), loosen the screw (6, Fig. 13) and turn the tension stud (7, Fig. 13) slightly to the left with a screw driver, or to lighten the tension, turn to the right.

Then tighten the screw and nut.

INSTRUCTION FOR THE MACHINES WITH SYNCHRONIZED BINDER

TAPING (Fig. 28)

Lift the serrated two nuts (1) slightly and open the plate (2) toward you. Pass the tape (3) alternately as indicated in the figure (28) through the tape guide (4).

Cut obliquely the edge of the tape and pass it through the binder (5) and draw it out about 2 cm.

If the tape has the right and wrong side, pass the tape the wrong side up. Then, close the plate (2).

ADJUSTING THE BINDER (Fig. 28)

The setting position of the binder depends on the shape of the binder, tape width, thickness of goods.

Accordingly, it is determined through actual sewing test.

To adjust this, loosen the nut (1), move the binder to the right or left to get proper position.

Then tighten the nut.

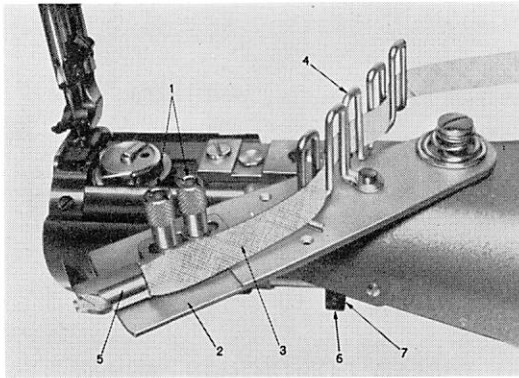

Fig. 28

RELATIVE POSITION OF THE BINDER TO THE FEEDER

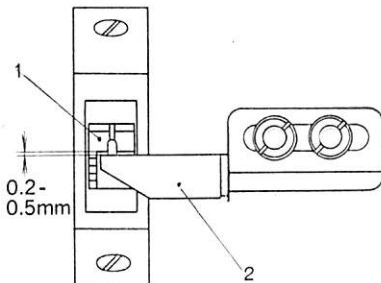

Fig. 29

Adjust the clearance between the feed dog (1, Fig. 29) and the binder (2, Fig. 29) from 0.2 to 0.5 mm. Tighten the screw (6, Fig. 28). Care must be taken that the part (7, Fig. 28) does not move axially when tightening the screw.

FINE ADJUSTMENT OF BINDER

Normally, the binder motion is synchronized with the feeding motion, but it is available to decrease or increase the motion of the binder.

To adjust this, loosen the screw (1), move the setting position of the pin (2) and (3).

To increase the motion, set the pin (2) shorter, and to decrease it, set the pin longer.

Then tighten the screw.

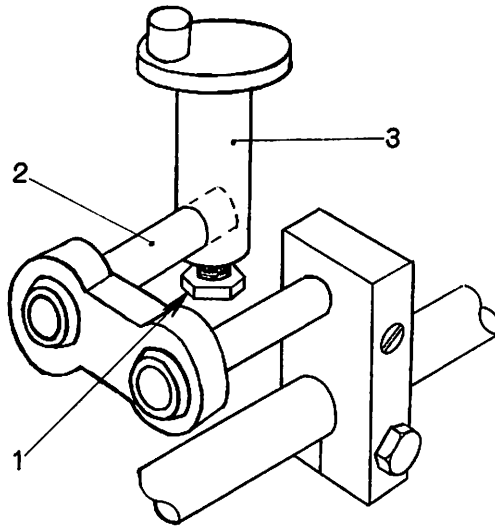

Fig. 30

